

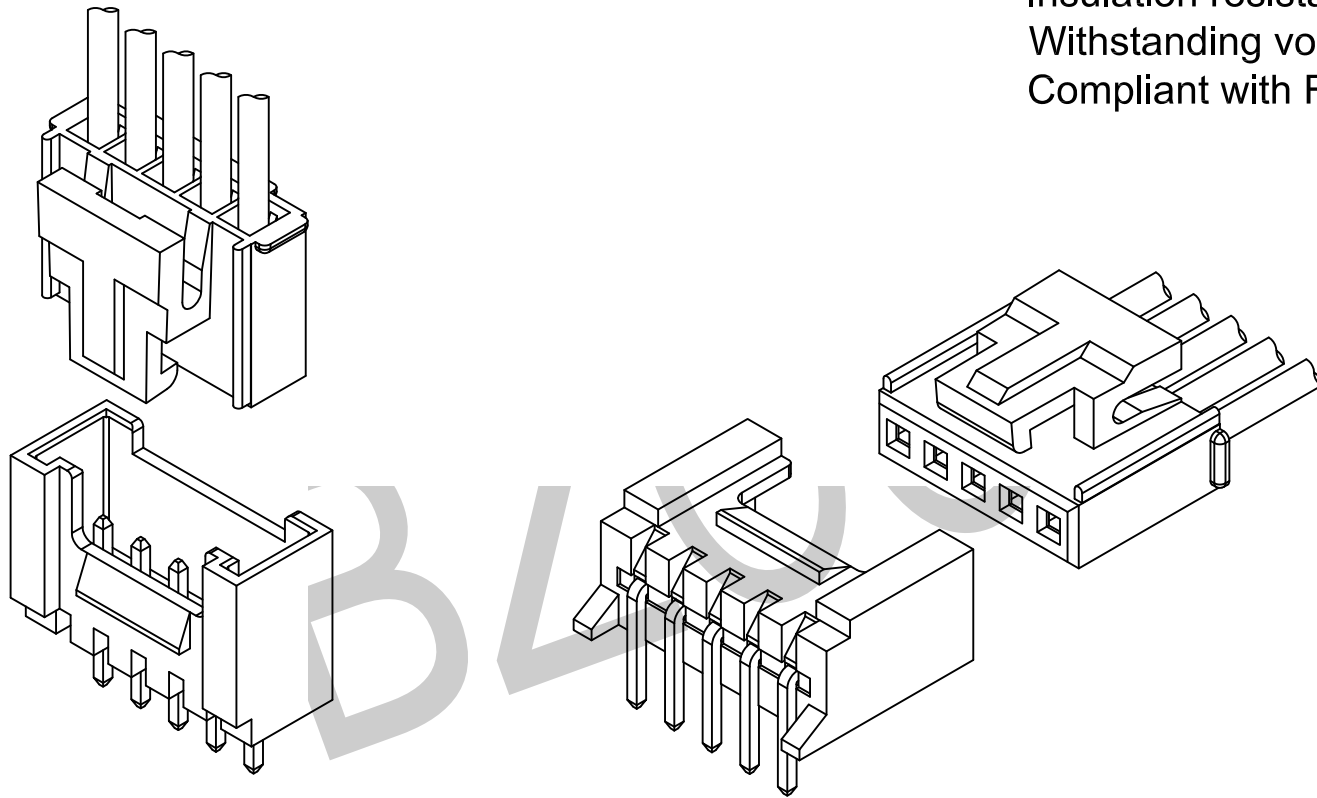

Current rating:3A AC,DC
 Voltage rating:250V AC,DC
 Temperature range:-40°C~+105°C
 Contact resistance:30mΩMax.
 Insulation resistance:1000MΩMin.
 Withstanding voltage:1000V AC/minute
 Compliant with RoHS and REACH



TOLERANCE UNLESS OTHERWISE SPECIFIED				BZOO 东莞市柏洲电子有限公司 Dongguan Bzoo Electronics, Ltd		APR. AX.T		TITLE: W200-01 TYPE WAFER	
.X± 0.35	X.*± 1.5*	.XX± 0.25		.X*± 1.0*		CHK. Y.L		PART NO.	
.XXX± 0.15	.XX*± 0.5*	A0	FIRST RELEASE	Y.L	2019.06.21	DRA. Y.L		UNITS. MM	SCALE: 1:1
REV.	ECN. NO.	APR.	DATE			PROJ.		CUSTOMER DRAWING	SHEET. 1 / 1



CURRENT RATING:3A AC,DC
 VOLTAGE RATING:250V AC,DC
 TEMPERATURE RANGE:-40°C~+105°C
 CONTACT RESISTANCE:30MΩMAX.
 INSULATION RESISTANCE:1000MΩMIN.
 WITHSTANDING VOLTAGE:1000V AC/MINUTE
 MATERIAL:NYLON 66,UL94V-0
 MATERIAL:PIN:BRASS/TIN OVER NICKEL

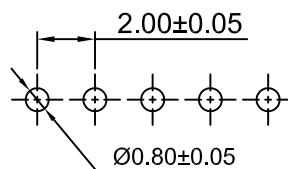
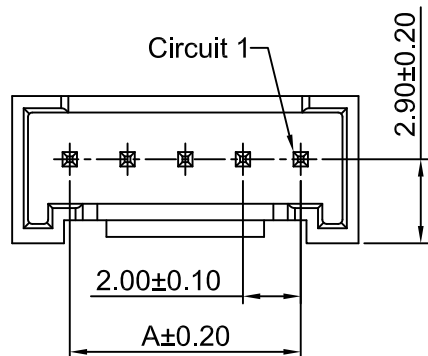
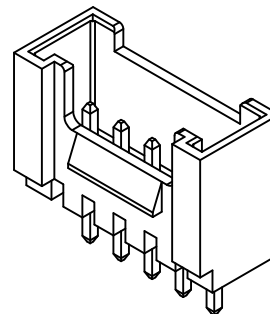

P.C.B LAYOUT

PIN NO.	Dimensions	
	A	B
2P	2.00	6.00
3P	4.00	8.00
4P	6.00	10.00
5P	8.00	12.00
6P	10.00	14.00
7P	12.00	16.00
8P	14.00	18.00
9P	16.00	20.00
10P	18.00	22.00
11P	20.00	24.00
12P	22.00	26.00
13P	24.00	28.00
14P	26.00	30.00
15P	28.00	32.00
16P	30.00	34.00

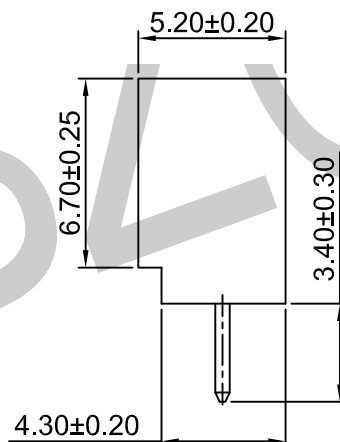
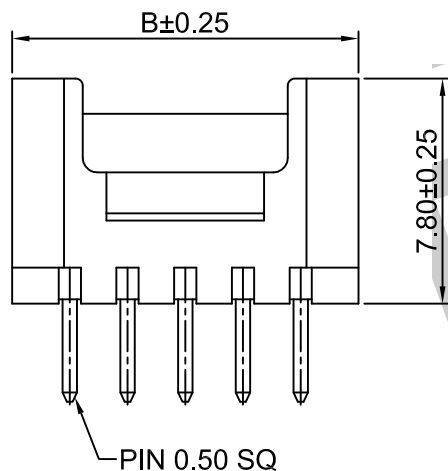

WAFER: W 200-010-1XX-WV-SN-C-P-PC-000
 200: 间距2.0mm
 01: WAFER TYPE1
 0: UL94V-0
 PIN: 102: 1*2P
 103: 1*3P

 116: 1*16P

WV: 180°
 流水码
 PC: 本色
 P: 袋装
 C: PA66
 SN: 镀锡

TOLERANCE UNLESS OTHERWISE SPECIFIED				东莞市柏洲电子有限公司 Dongguan BzooC Electronics, Ltd			
.X± 0.35	X.*± 1.5'	APR. AX.T	TITLE: PHD 2.00MM PITCH SINGLE ROW 180° TYPE1				
.XX± 0.25	.X*± 1.0'	CHK. Y.L	PART NO.				
.XXX± 0.15	.XX*± 0.5'	DRA. Y.L	PROJ.	UNITS. MM	SCALE: 1:1	SHEET. 1 / 1	
REV.	ECN. NO.	APR.	DATE	CUSTOMER DRAWING			

A0	FIRST RELEASE	Y.L	2019.06.21
REV.	ECN. NO.	APR.	DATE



CURRENT RATING:3A AC,DC
 VOLTAGE RATING:250V AC,DC
 TEMPERATURE RANGE:-40°C~+105°C
 CONTACT RESISTANCE:30MΩMAX.
 INSULATION RESISTANCE:1000MΩMIN.
 WITHSTANDING VOLTAGE:1000V AC/MINUTE
 MATERIAL:NYLON 66,UL94V-0
 MATERIAL:PIN:BRASS/TIN OVER NICKEL

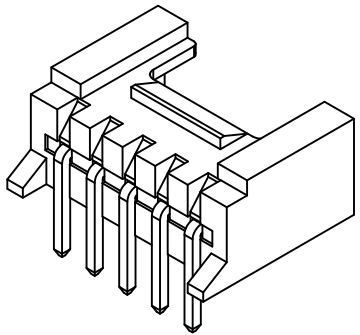
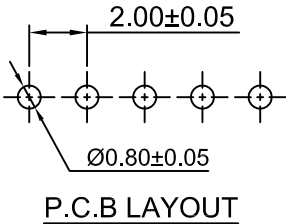
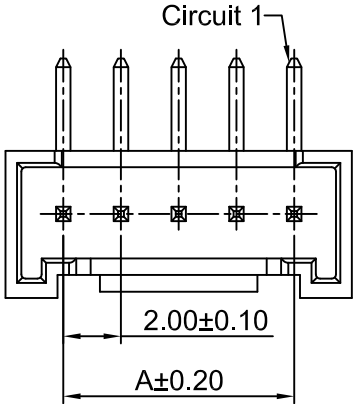

PIN NO.	Dimensions	
	A	B
2P	2.00	6.00
3P	4.00	8.00
4P	6.00	10.00
5P	8.00	12.00
6P	10.00	14.00
7P	12.00	16.00
8P	14.00	18.00
9P	16.00	20.00
10P	18.00	22.00
11P	20.00	24.00
12P	22.00	26.00
13P	24.00	28.00
14P	26.00	30.00
15P	28.00	32.00
16P	30.00	34.00

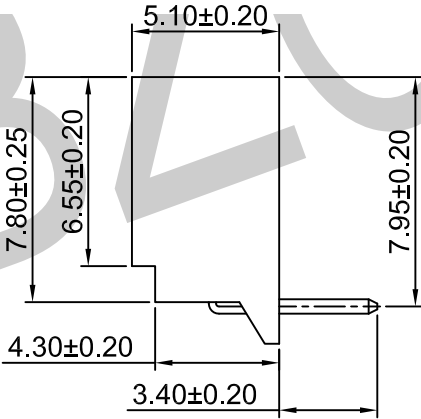
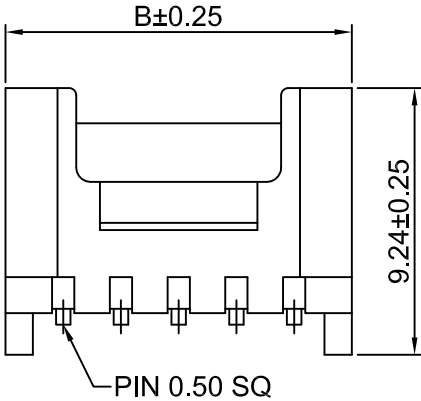

WAFER: W 200-010-1XX-WR-SN-C-P-PC-000
 200: 间距2.0mm
 01: WAFER TYPE1
 0: UL94V-0
 PIN: 102: 1*2P, 103: 1*3P, 116: 1*16P
 WR: 90°
 流水码
 PC: 本色
 P: 袋装
 C: PA66
 SN: 镀锡

TOLERANCE UNLESS OTHERWISE SPECIFIED				东莞市柏洲电子有限公司 Dongguan BzooC Electronics, Ltd	
.X± 0.35	X.*± 1.5*	APR. AX.T	TITLE: 2.00MM PITCH SINGLE ROW 90° TYPE1		
.XX± 0.25	.X*± 1.0*	CHK. Y.L	PART NO.		
.XXX± 0.15	.XX*± 0.5*	DRA. Y.L	PROJ.	UNITS. MM	SCALE: 1:1
REV.	ECN. NO.	APR.	DATE	CUSTOMER DRAWING	
A0	FIRST RELEASE	Y.L	2019.06.21	SHEET. 1 / 1	



CURRENT RATING:3A AC,DC
 VOLTAGE RATING:250V AC,DC
 TEMPERATURE RANGE:-40°C~+105°C
 CONTACT RESISTANCE:30MΩMAX.
 INSULATION RESISTANCE:1000MΩMIN.
 WITHSTANDING VOLTAGE:1000V AC/MINUTE
 MATERIAL:LCP,UL94V-0
 MATERIAL:PIN:BRASS/TIN OVER NICKEL

PIN NO.	Dimensions	
	A	B
2P	2.00	8.00
3P	4.00	10.00
4P	6.00	12.00
5P	8.00	14.00
6P	10.00	16.00
7P	12.00	18.00
8P	14.00	20.00
9P	16.00	22.00
10P	18.00	24.00
11P	20.00	26.00
12P	22.00	28.00
13P	24.00	30.00
14P	26.00	32.00
15P	28.00	34.00
16P	30.00	36.00

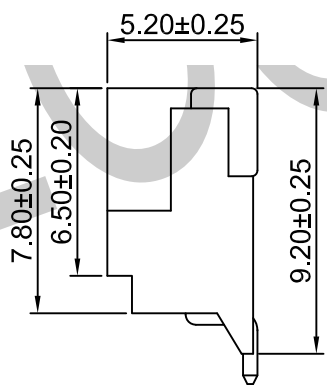
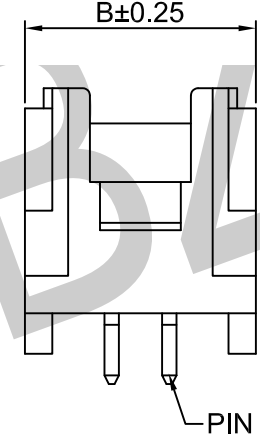
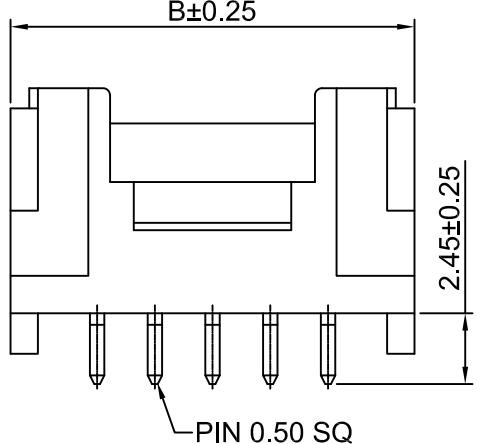
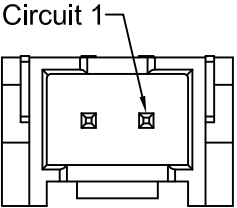
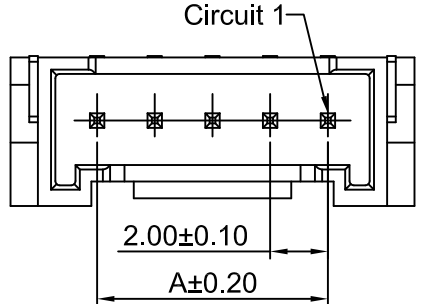
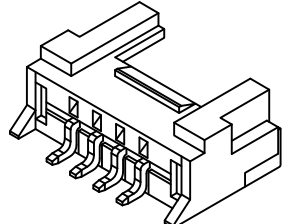
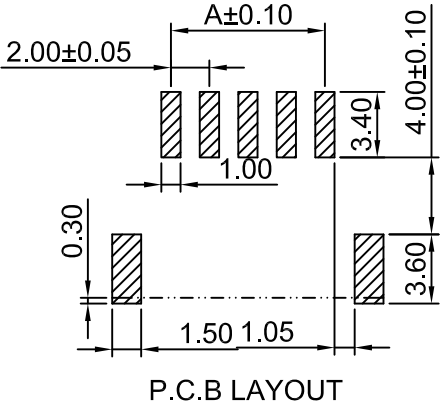

WAFER: W 200-010-1XX-WRS-SN-F-X-PC-000
 200:间距2.0mm
 01:WAFER TYPE1
 0:UL94V-0
 PIN:
 102:1*2P
 103:1*3P

 116:1*16P

WRS: 90° SMT
 流水码
 PC:本色
 T: 管装
 R: 卷装
 F:LCP
 SN:镀锡

TOLERANCE UNLESS OTHERWISE SPECIFIED				东莞市柏洲电子有限公司 Dongguan Bzoc Electronics, Ltd	
.X± 0.35	X.*± 1.5'	APR. AX.T	TITLE: 2.00MM PITCH SINGLE ROW 90°-SMT TYPE1		
.XX± 0.25	.X*± 1.0'	CHK. Y.L	PART NO.		
.XXX± 0.15	.XX*± 0.5'	DRA. Y.L	PROJ.	UNITS. MM	SCALE: 1:1
A0	FIRST RELEASE	Y.L	2019.06.21	SHEET. 1 / 1	
REV.	ECN. NO.	APR.	DATE	CUSTOMER DRAWING	



CURRENT RATING:3A AC,DC
 VOLTAGE RATING:250V AC,DC
 TEMPERATURE RANGE:-40°C~+105°C
 CONTACT RESISTANCE:30MΩMAX.
 INSULATION RESISTANCE:1000MΩMIN.
 WITHSTANDING VOLTAGE:1000V AC/MINUTE
 MATERIAL:LCP,UL94V-0
 MATERIAL:PIN:BRASS/TIN OVER NICKEL

PIN NO.	Dimensions		
	A	B	C
2P	2.00	4.75	8.00
3P	4.00	6.75	10.00
4P	6.00	8.75	12.00
5P	8.00	10.75	14.00
6P	10.00	12.75	16.00
7P	12.00	14.75	18.00
8P	14.00	16.75	20.00
9P	16.00	18.75	22.00
10P	18.00	20.75	24.00
11P	20.00	22.75	26.00
12P	22.00	24.75	28.00
13P	24.00	26.75	30.00
14P	26.00	28.75	32.00
15P	28.00	30.75	34.00
16P	30.00	32.75	36.00

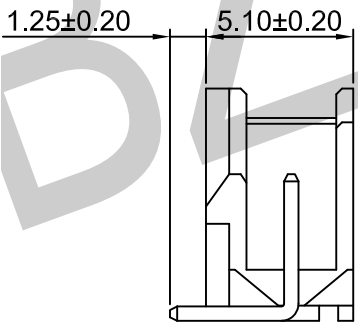
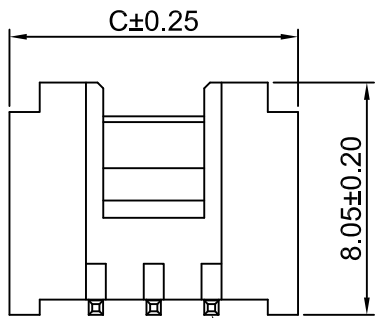
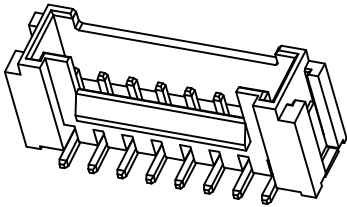
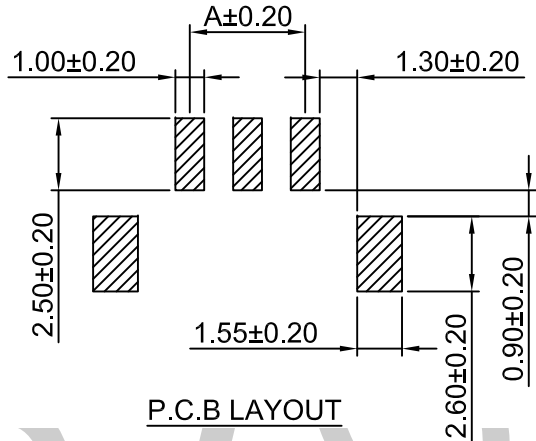
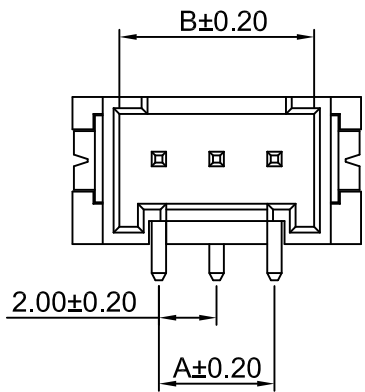

WAFER: W 200-010-1XX-WVS-SN-F-X-PC-000
 200: 间距2.0mm
 01: WAFER TYPE1
 0: UL94V-0
 PIN: 102: 1*2P, 103: 1*3P, ... 116: 1*16P
 180° SMT
 流水码
 PC: 本色
 T: 管装
 RC: 卷装+CAP
 F: LCP
 SN: 镀锡

TOLERANCE UNLESS OTHERWISE SPECIFIED		BZOO 东莞市柏洲电子有限公司 Dongguan Bzoo Electronics, Ltd	
.X± 0.35	X.*± 1.5'	APR. AX.T	TITLE: 2.00MM PITCH SINGLE ROW 180°-SMT TYPE1
.XX± 0.25	.X.*± 1.0'	CHK. Y.L	PART NO.
.XXX± 0.15	.XX.*± 0.5'	DRA. Y.L	PROJ.
A0	FIRST RELEASE	Y.L	2019.06.21
REV.	ECN. NO.	APR.	DATE
		UNITS. MM	SCALE: 1:1
		CUSTOMER DRAWING	
		SHEET. 1 / 1	

A0	FIRST RELEASE	Y.L	2019.06.21
REV.	ECN. NO.	APR.	DATE



CURRENT RATING:3A AC,DC
 VOLTAGE RATING:250V AC,DC
 TEMPERATURE RANGE:-40°C~+105°C
 CONTACT RESISTANCE:30MΩMAX.
 INSULATION RESISTANCE:1000MΩMIN.
 WITHSTANDING VOLTAGE:1000V AC/MINUTE

WIRE RANGE:AWG#22-#30
 INSULATION O.D.:1.45MM(MAX)
 QTY/REEL:10,000 PCS

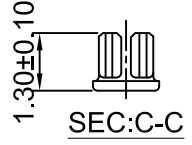
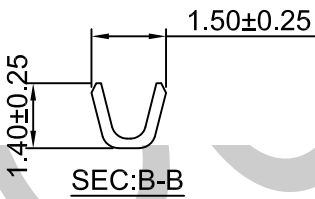
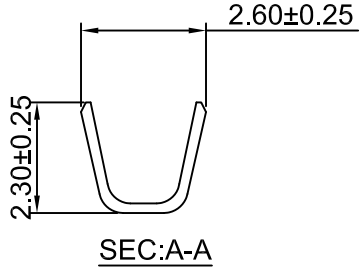
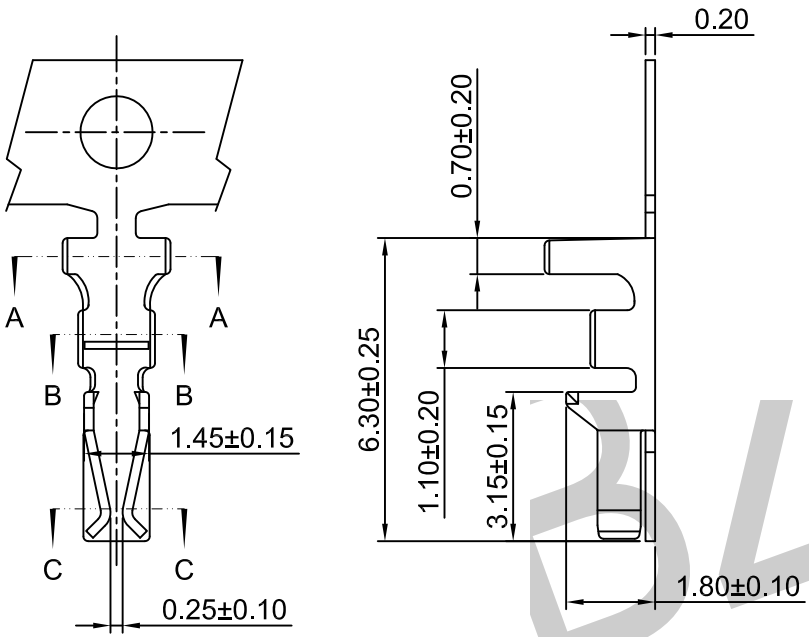

W 200-01F-PDJ-SN-000
 Wafer ———— Serial No.
 200:Pitch 2.0mm ———— SN:Tin Plating
 01:Wafer Type 1 ———— GF:Gold Plating
 F:Female Terminal ———— DJ:Low. PIN
 P:Phosphor Bronze

TOLERANCE UNLESS OTHERWISE SPECIFIED		BZOO 东莞市柏洲电子有限公司 Dongguan Bzoo Electronics, Ltd	
.X± 0.35	X.*± 1.5*	APR. AX.T	TITLE: 2.00MM PITCH SINGLE ROW CRIMP TERMINAL TYPE1
.XX± 0.25	.X.*± 1.0*	CHK. Y.L	PART NO.
.XXX± 0.15	.XX.*± 0.5*	DRA. Y.L	PROJ.
A0	FIRST RELEASE	Y.L	2019.06.21
REV.	ECN. NO.	APR.	DATE
UNITS: MM		SCALE: 1:1	SHEET. 1 / 1
CUSTOMER DRAWING			

A0	FIRST RELEASE	Y.L	2019.06.21
REV.	ECN. NO.	APR.	DATE



CURRENT RATING:3A AC,DC
 VOLTAGE RATING:250V AC,DC
 TEMPERATURE RANGE:-40°C~+105°C
 CONTACT RESISTANCE:30MΩMAX.
 INSULATION RESISTANCE:1000MΩMIN.
 WITHSTANDING VOLTAGE:1000V AC/MINUTE
 MATERIAL:NYLON 66,UL94V-0

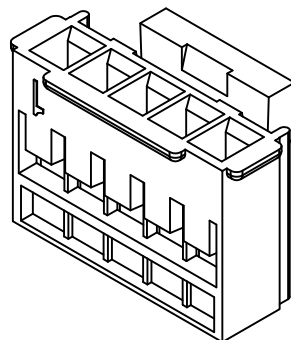
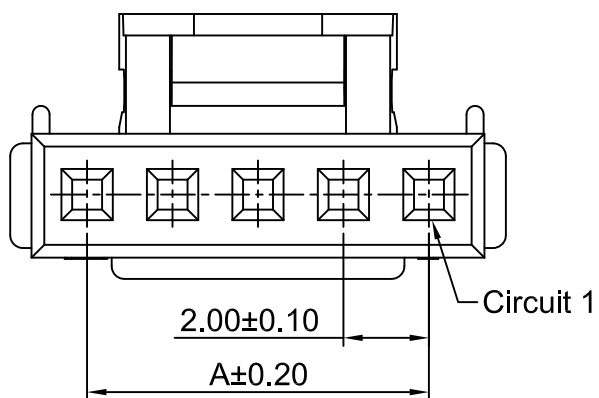

PIN NO.	Dimensions	
	A	B
2P	2.00	4.70
3P	4.00	6.70
4P	6.00	8.70
5P	8.00	10.70
6P	10.00	12.70
7P	12.00	14.70
8P	14.00	16.70
9P	16.00	18.70
10P	18.00	20.70
11P	20.00	22.70
12P	22.00	24.70
13P	24.00	26.70
14P	26.00	28.70
15P	28.00	30.70
16P	30.00	32.70

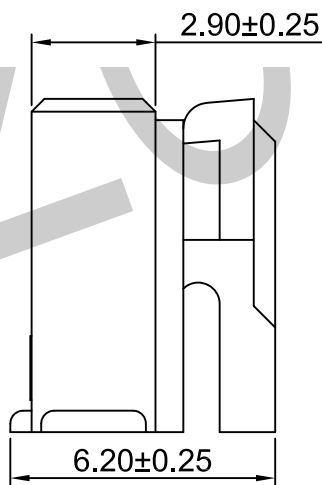
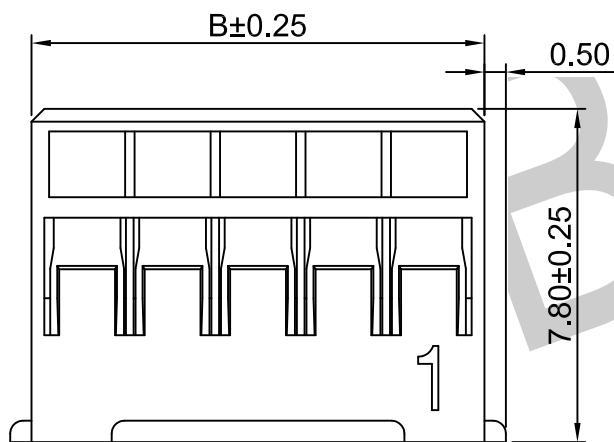

WAFER **W 200-010-1XX-HM-WE-C-P-000** SERIAL NO.
 200:间距2.00mm P: PACKING: BAG
 01:WAFER TYPE 1 C:PA66
 0:UL94V-0 WE: WHITE
 PIN NO. : HM:MALE HOUSING
 102:1*2P
 103:1*3P
 ...
 116:1*16P

TOLERANCE UNLESS OTHERWISE SPECIFIED		BZOO 东莞市柏洲电子有限公司 Dongguan Bzoo Electronics, Ltd	
.X± 0.35	X.*± 1.5'	APR. AX.T	TITLE: 2.00MM PITCH SINGLE ROW HOUSING TYPE1 H:7.8
.XX± 0.25	.X.*± 1.0'	CHK. Y.L	PART NO.
.XXX± 0.15	.XX.*± 0.5'	DRA. Y.L	PROJ.
A0	FIRST RELEASE	Y.L	2019.06.21
REV.	ECN. NO.	APR.	DATE
		UNITS. MM	SCALE: 1:1
		CUSTOMER DRAWING	
		SHEET. 1 / 1	

A0	FIRST RELEASE	Y.L	2019.06.21
REV.	ECN. NO.	APR.	DATE