

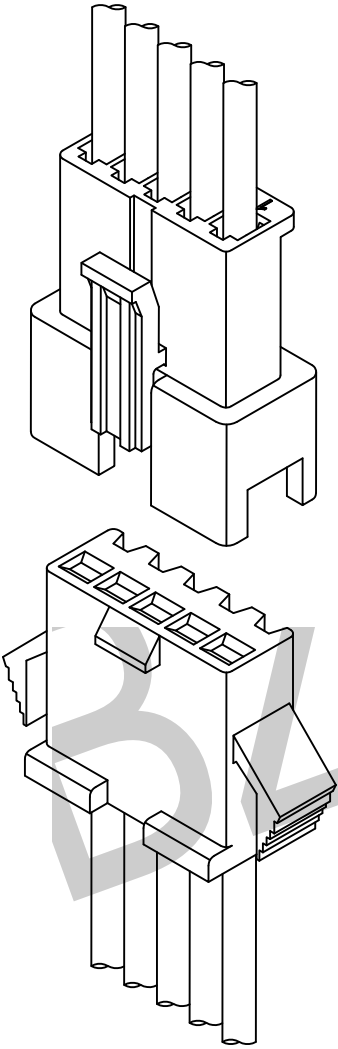

Current rating:3A AC,DC
 Voltage rating:250V AC,DC
 Temperature range:-40°C~+105°C
 Contact resistance:10mΩ Max.
 Insulation resistance:500MΩ Min.
 Withstanding voltage:1500V AC/minute
 Compliant with RoHS and REACH



TOLERANCE UNLESS OTHERWISE SPECIFIED		BZOO 东莞市柏洲电子有限公司 Dongguan Bzoo Electronics, Ltd	
.X± 0.35	X.*± 1.5*	APR. AX.T	TITLE: W250-06 TYPE WAFER
.XX± 0.25	.X*± 1.0*	CHK. Y.L	PART NO.
.XXX± 0.15	.XX*± 0.5*	DRA. Y.L	PROJ. UNITS: MM SCALE: 1:1 SHEET. 1 / 1
CUSTOMER DRAWING			

A0	FIRST RELEASE	Y.L	2019.06.21
REV.	ECN. NO.	APR.	DATE



PIN NO.	Dimensions	
	A	B
02P	2.50	5.50
03P	5.00	8.00
04P	7.50	10.50
05P	10.00	13.00
06P	12.50	15.50
07P	15.00	18.00
08P	17.50	20.50
09P	20.00	23.00
10P	22.50	25.50
11P	25.00	28.00
12P	27.50	30.50

Current rating:3A AC,DC
 Voltage rating:250V AC,DC
 Temperature range:-40°C~+105°C
 Contact resistance:10mΩ Max.
 Insulation resistance:500MΩ Min.
 Withstanding voltage:1500V AC/minute
 Material:Nylon 66,UL94V-0

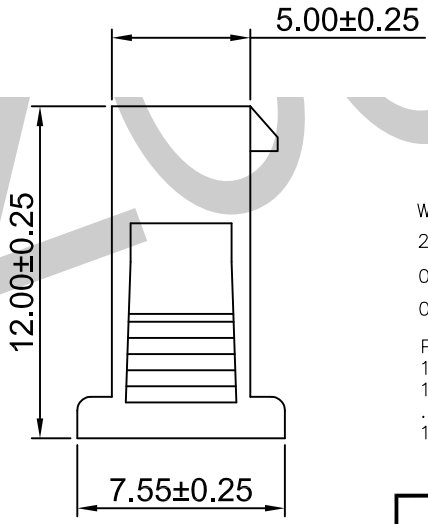
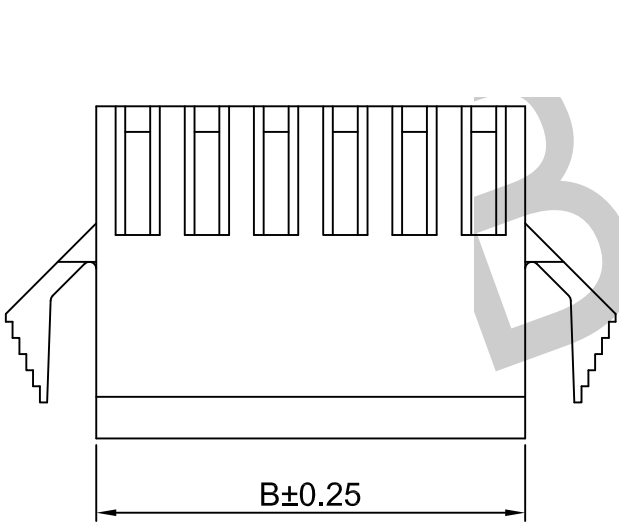
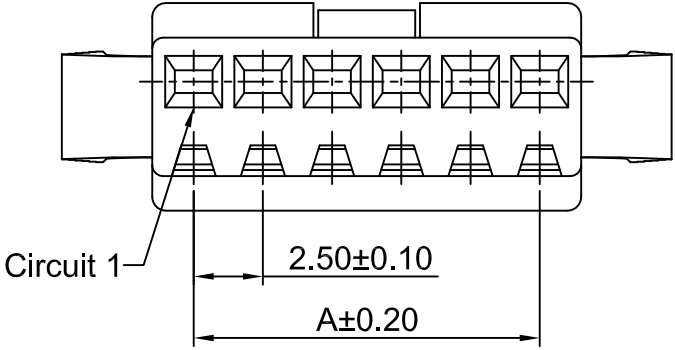
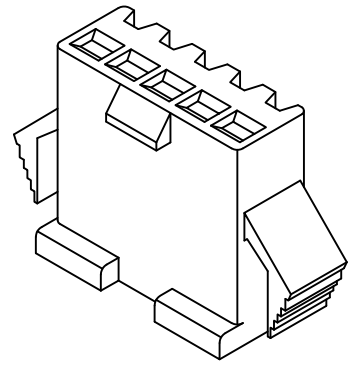

WAFER W 250-060-1XX-HF-BK-C-P-000 SERIAL NO.
 250:间距2.5MM PACKING:BAG
 06:WAFER TYPE6 C:PA66
 0:UL94V-0 BLACK
 PIN NO.: 102:1*2P HF:FEMALE HOUSING
 103:1*3P
 ...
 112:1*12P

TOLERANCE UNLESS OTHERWISE SPECIFIED		BZOO 东莞市柏洲电子有限公司 Dongguan Bzoo Electronics, Ltd	
.X± 0.35	X.*± 1.5*	APR. AX.T	TITLE: 2.50MM PITCH SINGLE ROW FEMALE HOUSING TYPE6
.XX± 0.25	.X.*± 1.0*	CHK. Y.L	PART NO.
.XXX± 0.15	.XX.*± 0.5*	DRA. Y.L	PROJ.
A0	FIRST RELEASE	Y.L	2019.06.21
REV.	ECN. NO.	APR.	DATE
UNITS. MM		SCALE: 1:1	SHEET. 1 / 1
CUSTOMER DRAWING			

A0	FIRST RELEASE	Y.L	2019.06.21
REV.	ECN. NO.	APR.	DATE



Current rating:3A AC,DC
 Voltage rating:250V AC,DC
 Temperature range:-40°C~+105°C
 Contact resistance:10mΩ Max.
 Insulation resistance:500MΩ Min.
 Withstanding voltage:1500V AC/minute
 Material:Brass/Phosphor Bronze
 Wire Range:AWG#22-#28
 Insulation O.D.:1.80mm(max)
 Qty/reel:7,000 PCS

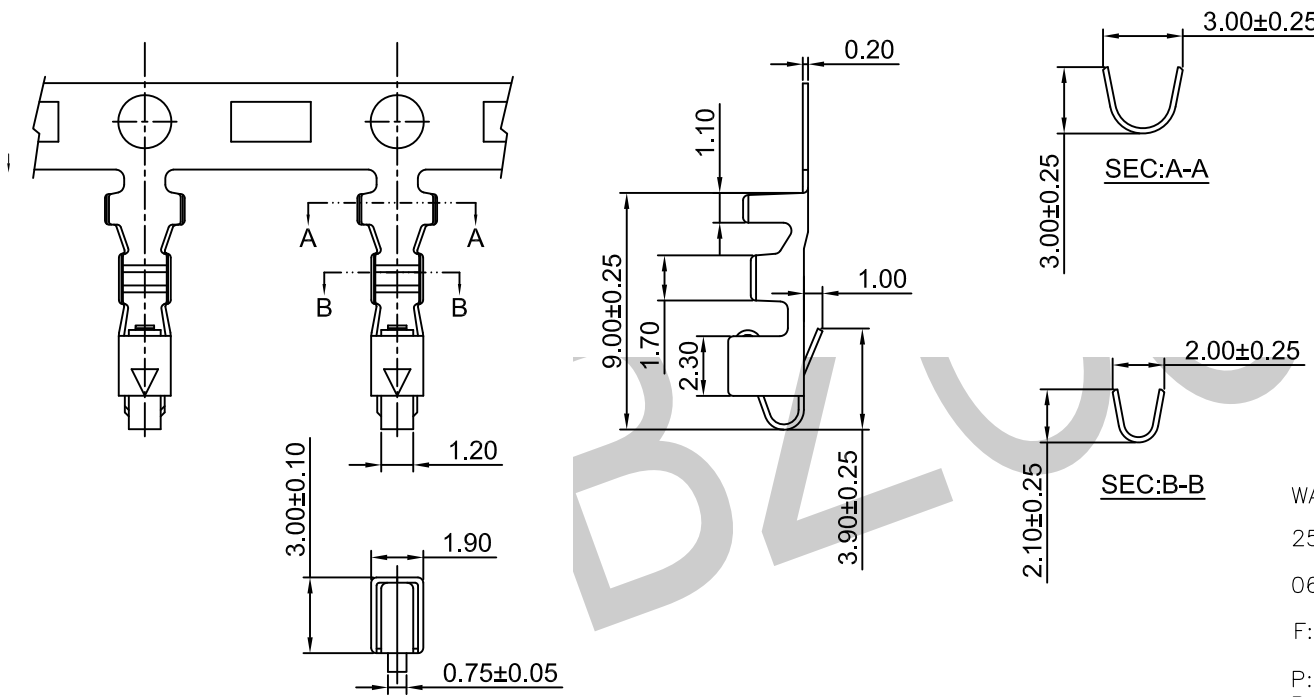

WAFER _____ W 250-06F-XDJ-SN-000 SERIAL NO.
 250:PITCH 2.5MM _____ SN:TIN PLATING
 06:WAFER TYPE6 _____ GF:GOLD PLATING
 F:FEMALE TERMINAL _____ DJ:LOW. PIN
 P:PHOSPHOR BRONZE _____
 B:BRASS _____

A0	FIRST RELEASE	Y.L	2019.06.21
REV.	ECN. NO.	APR.	DATE

TOLERANCE UNLESS OTHERWISE SPECIFIED		东莞市柏洲电子有限公司 Dongguan BzooC Electronics, Ltd	
.X± 0.35	X.*± 1.5*	APR. AX.T	TITLE: 2.50MM PITCH CRIMP FEMALE TERMINAL TYPE6
.XX± 0.25	.X*± 1.0*	CHK. Y.L	PART NO.
.XXX± 0.15	.XX*± 0.5*	DRA. Y.L	PROJ. UNITS. MM SCALE: 1:1 CUSTOMER DRAWING SHEET. 1 / 1



PIN NO.	Dimensions	
	A	B
02P	2.50	8.00
03P	5.00	10.50
04P	7.50	13.00
05P	10.00	15.50
06P	12.50	18.00
07P	15.00	20.50
08P	17.50	23.00
09P	20.00	25.50
10P	22.50	28.00
11P	25.00	30.50
12P	27.50	33.00

Current rating:3A AC,DC
 Voltage rating:250V AC,DC
 Temperature range:-40°C~+105°C
 Contact resistance:10mΩ Max.
 Insulation resistance:500MΩ Min.
 Withstanding voltage:1500V AC/minute
 Material:Nylon 66,UL94V-0

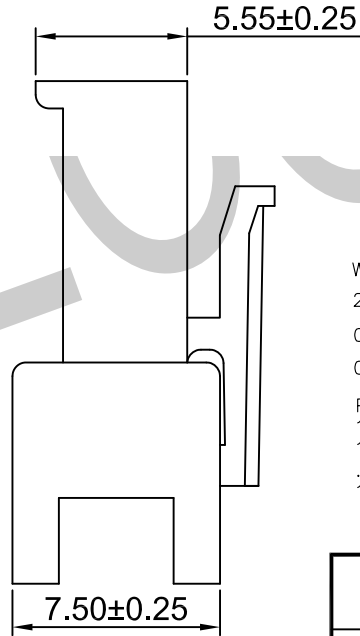
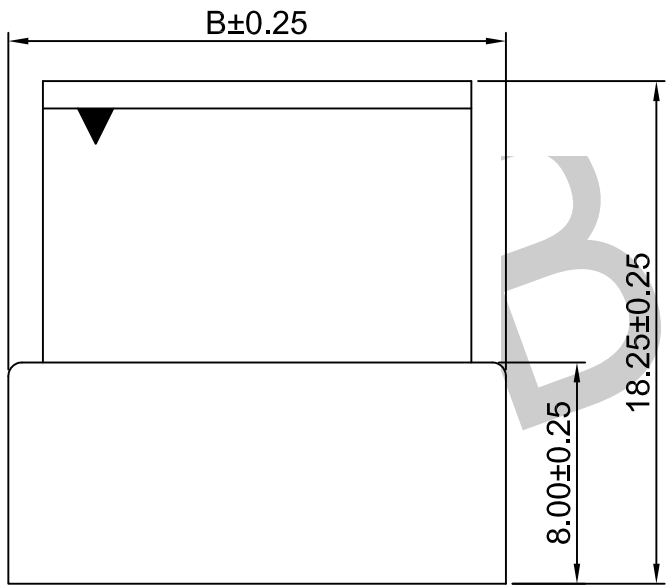
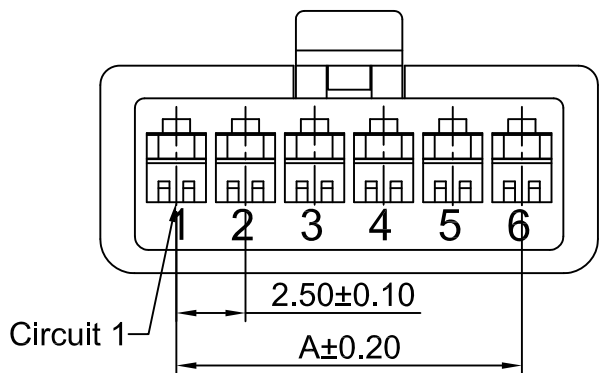
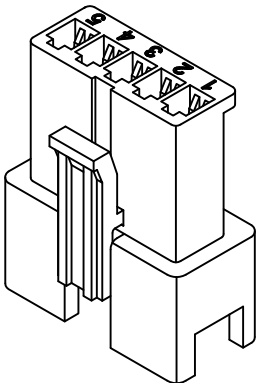

W 250-060-1XX-HM-BK-C-P-000
 WAFFER SERIAL NO.
 250:间距2.5MM PACKING:BAG
 06:WAFFER TYPE6 C:PA66
 0:UL94V-0 BLACK
 PIN NO.:
 102:1*2P
 103:1*3P
 ...
 112:1*12P
 HM:MALE HOUSING

TOLERANCE UNLESS OTHERWISE SPECIFIED		BZOO 东莞市柏洲电子有限公司 Dongguan Bzoo Electronics, Ltd	
.X± 0.35	X.*± 1.5*	APR. AX.T	TITLE: 2.50MM PITCH SINGLE ROW MALE HOUSING TYPE6
.XX± 0.25	.X*± 1.0*	CHK. Y.L	PART NO.
.XXX± 0.15	.XX*± 0.5*	DRA. Y.L	PROJ.
UNITS: MM		SCALE: 1:1	SHEET. 1 / 1
CUSTOMER DRAWING			

A0	FIRST RELEASE	Y.L	2019.06.21
REV.	ECN. NO.	APR.	DATE



Current rating:3A AC,DC
 Voltage rating:250V AC,DC
 Temperature range:-40°C~+105°C
 Contact resistance:10mΩ Max.
 Insulation resistance:500MΩ Min.
 Withstanding voltage:1500V AC/minute
 Material:Brass/Phosphor Bronze
 Wire Range:AWG#22-#28
 Insulation O.D.:1.80mm(max)
 Qty/reel:10,000 PCS

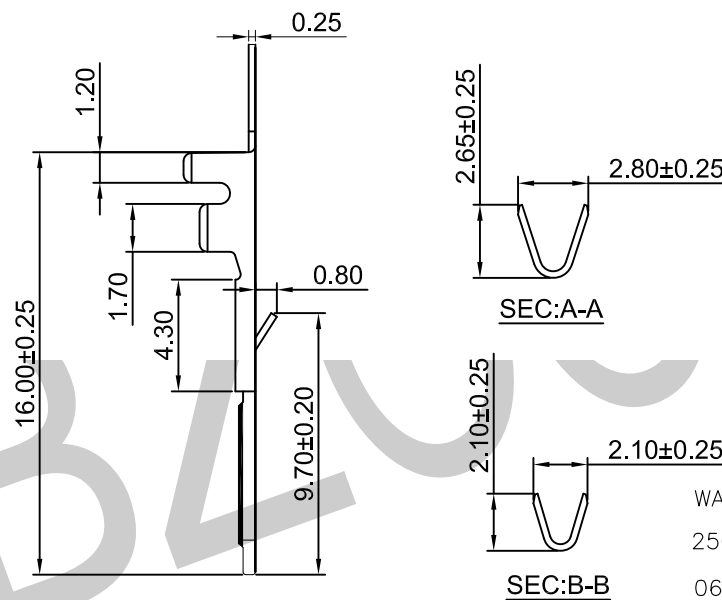
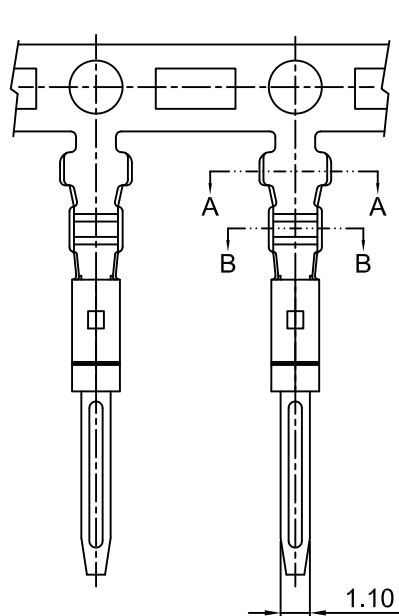

W 250-06M-XDJ-SN-000 SERIAL NO.
 250:PITCH 2.5MM
 06:WAFER TYPE6
 M:MALE TERMINAL
 P:PHOSPHOR BRONZE
 B:BRASS
 SN:TIN PLATING
 GF:GOLD PLATING
 DJ:LOW. PIN

TOLERANCE UNLESS OTHERWISE SPECIFIED				东莞市柏洲电子有限公司 Dongguan BzooC Electronics, Ltd	
.X± 0.35	X.*± 1.5*	APR. AX.T	TITLE: 2.50MM PITCH CRIMP MALE TERMINAL TYPE6		
.XX± 0.25	.X*± 1.0*	CHK. Y.L	PART NO.		
.XXX± 0.15	.XX*± 0.5*	DRA. Y.L	PROJ.	UNITS. MM	SCALE: 1:1
A0	FIRST RELEASE	Y.L	2019.06.21	CUSTOMER DRAWING	
REV.	ECN. NO.	APR.	DATE	SHEET. 1 / 1	