

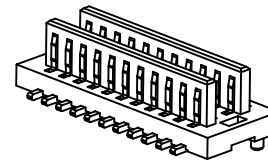

NOTES:

- HUOSING: PA9T HIGH-TEMP THERMOPLASTIC UL94V-0 COLOR:BLACK
- TERMINAL:PHOSPHOR BRONZE
PLATING:1μ'' GOLD FLASH OVERALL 50~100μ'' NICKEL UNDER PLATED.

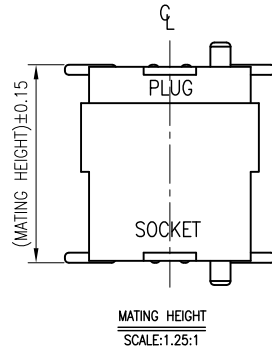
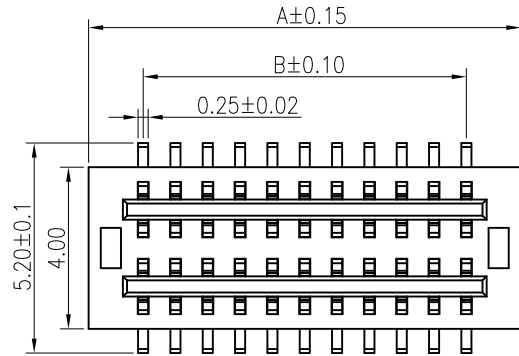

MATING HEIGHT	PLUG (H.)	SOCKET (H.)
4.0	1.0	3.0
4.5	1.0	3.5
5.0	1.0	4.0
5.5	1.0	4.5
6.0	2.0	4.0
6.5	2.0	4.5
7.0	4.0	3.0
7.5	4.0	3.5
8.0	4.0	4.0
8.5	4.0	4.5

NO.of contacts	Dimensions				NO.of contacts	Dimensions			
	A.	B.	C.	D.		A.	B.	C.	D.
H1.0~2.0	5.10	2.40	3.40	4.20	54	23.50	20.80	21.80	22.60
8					56	24.30	21.60	22.60	23.40
10	5.90	3.20	4.20	5.00	58	25.10	22.40	23.40	24.20
12	6.70	4.00	5.00	5.80	60	25.90	23.20	24.20	25.00
14	7.50	4.80	5.80	6.60	62	26.70	24.00	25.00	25.80
16	8.30	5.60	6.60	7.40	64	27.50	24.80	25.80	26.60
18	9.10	6.40	7.40	8.20	66	28.30	25.60	26.60	27.40
20	9.90	7.20	8.20	9.00	68	29.10	26.40	27.40	28.20
22	10.70	8.00	9.00	9.80	70	29.90	27.20	28.20	29.00
24	11.50	8.80	9.80	10.60	72	30.70	28.00	29.00	29.80
26	12.30	9.60	10.60	11.40	74	31.50	28.80	29.80	30.60
28	13.10	10.40	11.40	12.20	76	32.30	29.60	30.60	31.40
30	13.90	11.20	12.20	13.00	78	33.10	30.40	31.40	32.20
32	14.70	12.00	13.00	13.80	80	33.90	31.20	32.20	33.00
34	15.50	12.80	13.80	14.60	82	34.70	32.00	33.00	33.80
36	16.30	13.60	14.60	15.40	84	35.50	32.80	33.80	34.60
38	17.10	14.40	15.40	16.20	86	36.30	33.60	34.60	35.40
40	17.90	15.20	16.20	17.00	88	37.10	34.40	35.40	36.20
42	18.70	16.00	17.00	17.80	90	37.90	35.20	36.20	37.00
44	19.50	16.80	17.80	18.60	92	38.70	36.00	37.00	37.80
46	20.30	17.60	18.60	19.40	94	39.50	36.80	37.80	38.60
48	21.10	18.40	19.40	20.20	96	40.30	37.60	38.60	39.40
50	21.90	19.20	20.20	21.00	98	41.10	38.40	39.40	40.20
					100	41.90	39.20	40.20	41.00

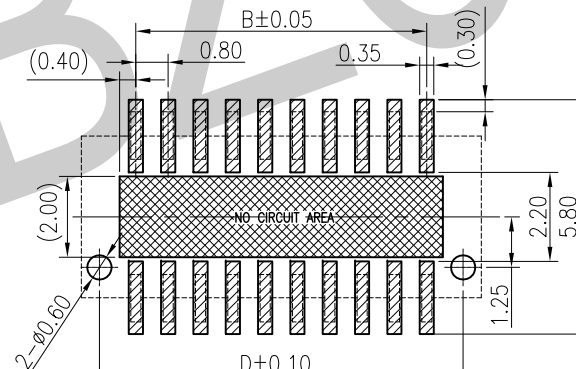
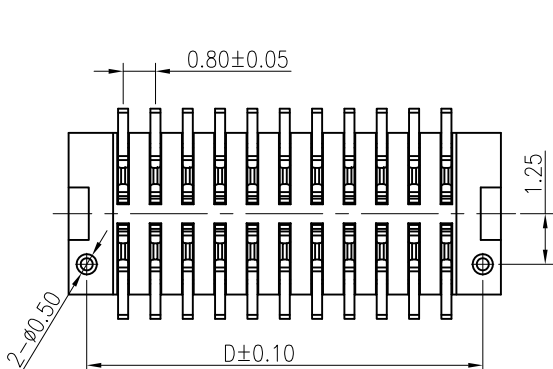
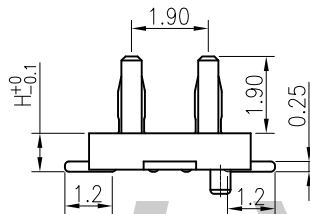
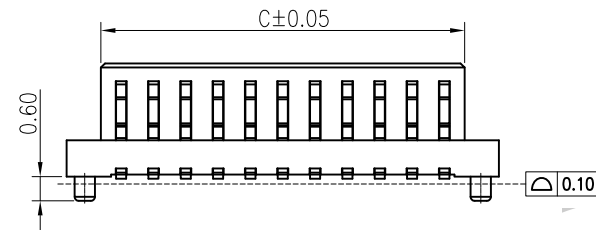

RECOMMENDED PCB PATTERN DIM.
TOLERANCE : ±0.05

BT 080-02-OXX-2XX-M-WVS-G1-E-RC-OXX-BK-000
 板对板
 间距:0.8MM
 02系列
 塑胶高度:
 010:1.0
 020:2.0
 PIN数:
 204:2*4P
 205:2*5P

 250:2*50P
 M:公座
 流水码
 颜色:黑色
 RC:卷装+CAP
 E:PA9T
 G1:镀金 1U''
 180° SMT
 板对板合高:
 040:4.0
 045:4.5
 050:5.0
 055:5.5
 060:6.0
 065:6.5
 070:7.0
 075:7.5
 080:8.0
 085:8.5

TOLERANCE UNLESS OTHERWISE SPECIFIED		BZOC 东莞市柏洲电子有限公司 Dongguan Bzoc Electronics, Ltd	
.X± 0.35	X.*± 1.5'	APR. AX.T	TITLE: 0.8MM 02系列 板对板 双槽 公座
.XX± 0.25	.X*± 1.0'	CHK. Y.L	PART NO.
.XXX± 0.15	.XX*± 0.5'	DRA. Y.L	PROJ. UNITS. MM SCALE: 1:1 SHEET. 1/1
REV.	ECN. NO.	APR.	DATE

A0	FIRST RELEASE	Y.L	2019.06.21
REV.	ECN. NO.	APR.	DATE



NOTES:

- HUOSING: PA9T HIGH-TEMP THERMOPLASTIC UL94V-0 COLOR:BLACK
- TERMINAL:PHOSPHOR BRONZE
PLATING:1μ'' GOLD FLASH OVERALL 50~100 μ'' NICKEL UNDER PLATED.

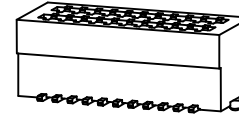
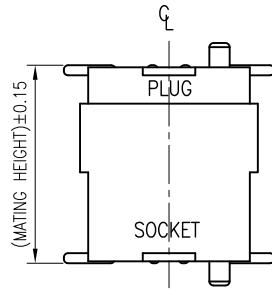
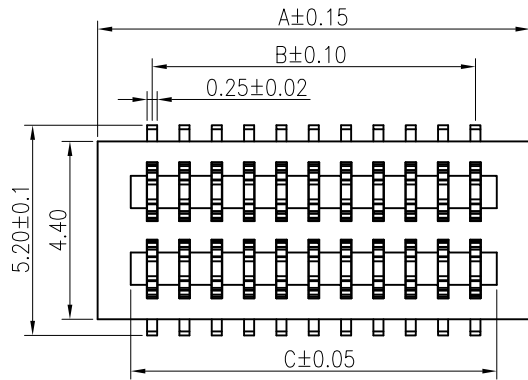

MATING HEIGHT	PLUG (H.)	SOCKET (H.)
4.0	1.0	3.0
4.5	1.0	3.5
5.0	1.0	4.0
5.5	1.0	4.5
6.0	2.0	4.0
6.5	2.0	4.5
7.0	4.0	3.0
7.5	4.0	3.5
8.0	4.0	4.0
8.5	4.0	4.5

NO.of contacts	Dimensions				NO.of contacts	Dimensions			
	A.	B.	C.	D.		A.	B.	C.	D.
8	5.10	2.40	3.46	4.20	54	23.50	20.80	21.86	22.60
10	5.90	3.20	4.26	5.00	56	24.30	21.60	22.66	23.40
12	6.70	4.00	5.06	5.80	58	25.10	22.40	23.46	24.20
14	7.50	4.80	5.86	6.60	60	25.90	23.20	24.26	25.00
16	8.30	5.60	6.66	7.40	62	26.70	24.00	25.06	25.80
18	9.10	6.40	7.46	8.20	64	27.50	24.80	25.86	26.60
20	9.90	7.20	8.26	9.00	66	28.30	25.60	26.66	27.40
22	10.70	8.00	9.06	9.80	68	29.10	26.40	27.46	28.20
24	11.50	8.80	9.86	10.60	70	29.90	27.20	28.26	29.00
26	12.30	9.60	10.66	11.40	72	30.70	28.00	29.06	29.80
28	13.10	10.40	11.46	12.20	74	31.50	28.80	29.86	30.60
30	13.90	11.20	12.26	13.00	76	32.30	29.60	30.66	31.40
32	14.70	12.00	13.06	13.80	78	33.10	30.40	31.46	32.20
34	15.50	12.80	13.86	14.60	80	33.90	31.20	32.26	33.00
36	16.30	13.60	14.66	15.40	82	34.70	32.00	33.06	33.80
38	17.10	14.40	15.46	16.20	84	35.50	32.80	33.86	34.60
40	17.90	15.20	16.26	17.00	86	36.30	33.60	34.66	35.40
42	18.70	16.00	17.06	17.80	88	37.10	34.40	35.46	36.20
44	19.50	16.80	17.86	18.60	90	37.90	35.20	36.26	37.00
46	20.30	17.60	18.66	19.40	92	38.70	36.00	37.06	37.80
48	21.10	18.40	19.46	20.20	94	39.50	36.80	37.86	38.60
50	21.90	19.20	20.26	21.00	96	40.30	37.60	38.66	39.40
					98	41.10	38.40	39.46	40.20
					100	41.90	39.20	40.26	41.00

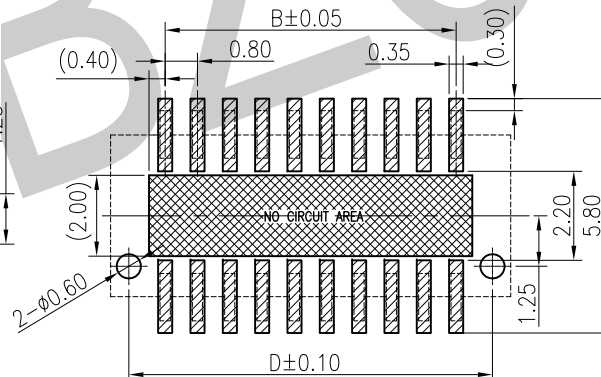
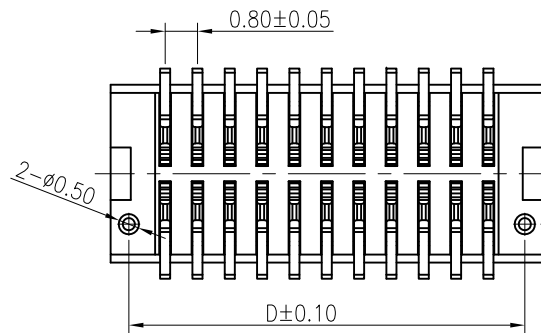
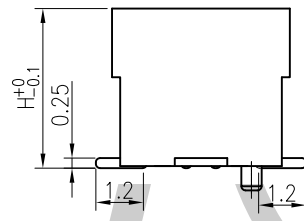
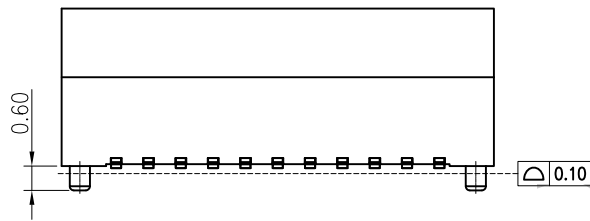

RECOMMENDED PCB PATTERN DIM.
TOLERANCE : ±0.05

A0	FIRST RELEASE	Y.L	2019.06.21
REV.	ECN. NO.	APR.	DATE

BT 080-02-OXX-2XX-F-WVS-G1-E-RC-OXX-BK-000

板对板
间距:0.8MM
02系列
塑胶高度:
030:3.0
035:3.5
040:4.0
045:4.5

流水码
颜色:黑色

板对板合高:
040:4.0
045:4.5
050:5.0
055:5.5
060:6.0
065:6.5
070:7.0
075:7.5
080:8.0
085:8.5

RC: 卷装+CAP
E:PA9T
G1: 镀金 1U"
180° SMT

PIN数:
204:2*4P
205:2*5P
.....
250:2*50P

F: 母座

TOLERANCE UNLESS OTHERWISE SPECIFIED		BZOO 东莞市柏洲电子有限公司 Dongguan Bzoo Electronics, Ltd	
.X± 0.35	X.'± 1.5'	APR. AX.T	TITLE: 0.8MM 02系列 板对板 双槽 母座
.XX± 0.25	.X*± 1.0'	CHK. Y.L	PART NO.
.XXX± 0.15	.XX*± 0.5'	DRA. Y.L	PROJ.
			UNITS. MM SCALE: 1:1 CUSTOMER DRAWING SHEET. 1 / 1